

Suprema Leo screen

Suprema Leo screen



Specifications

Format	4:3		1:1	
Model	PT-H100	PT-H60	PT-H70	PT-H84
Specification(in)	100	60x60	70x70	84x84
Viewing Area WxH	mm	2030x1520	1520x1520	1720x1720
	in	79-15/16x59-27/32	59-27/32x59-27/32	67-23/32x67-23/32
L total length	mm	2192	1665	1863
	in	86-19/64	65-9/16	73-11/32
A size	mm	2225	1705	1896
	in	87-19/32	67-1/8	74-21/32
B1 size	mm	40	30	40
	in	1-9/16	1-3/16	1-3/16
Packaging LxWxH	mm	2370x175x110	1843x175x110	2041x175x110
	in	93-5/16x6-7/8x4-11/32	72-9/16x6-7/8x4-11/32	80-5/16x6-7/8x4-11/32
Net Weight (kg)	8.7	6.8	7.8	9.2
Gross Weight (Kg)	10.9	8.6	9.7	11.4
Optional Screen Fabrics				
WM8	✓	✓	✓	✓
WM7	✓	✓	✓	✓
GB8	✓	✓	✓	✓

Sizes and specifications are subject to change at anytime. [The tolerance for L is about ±5mm(3/16in)]

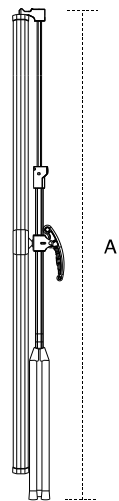
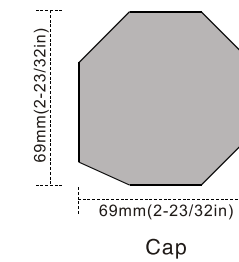
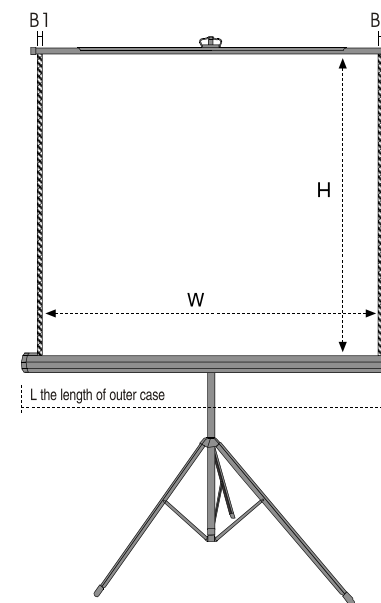

Part View



Product features >>

- Trendy and Elegant** (Figure 1)
 The stylish black painted case could prevent reflecting projected light.
- Adjustable Stand** (Figure 2)
 The adjustable stand allows various heights suitable for every audience's need.
- Lightweight** (Figure 3)
 The design is compact and lightweight, ideal for a portable unit. Even though the screen is 80 inches, it only weighs about 6 kg.
- Special Design** (Figure 4,5)
 The user-friendly plastic handle can be used for many purposes such as portability and for height adjustment.
- Keystone Feature** (Figure 6)
 The compact and unique tripod design meets international standards. The special keystone adjustment enables all views from various angles.

